

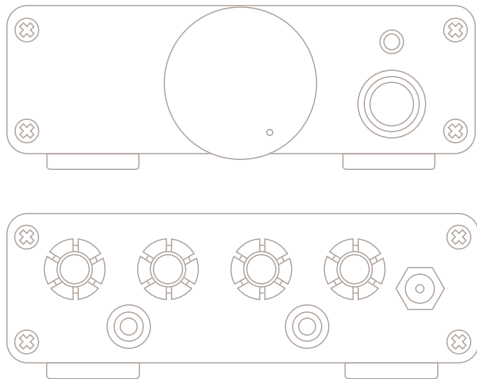

Temple Audio Bantam Integrated Amplifier



Users Manual 2.0



Introducing the Bantam...

An audiophile quality, class T integrated amplifier. Hand assembled in the UK to the highest standards.

Like many audio enthusiasts, we have been impressed by the clarity offered by Class T designs from Tripath.

With the Bantam, we take that design to the next level.

The combination of state of the art digital amplification technology with a stylish aluminum exterior and heavy duty gold plated connectors throughout the audio path, means that the Bantam is more than a match for any high end audio equipment that might cost ten times the price.

True to its name, it really does punch above its weight.

Contents

- 4 - Contents of Package
- 5 - Setting Up
- 6 - Connection
- 7 - Connection Diagram
- 8 - Controls
- 9 - Optimisation
- 10 - Trouble Shooting
- 11 - Warranty Information
- 12 - Contact Details

Contents of Package

- 1 Bantam Amplifier Unit
- 1 Stereo 3.5m Headphone Jack to Dual Phono Cable
- 1 Power Supply (optional)



Setting up

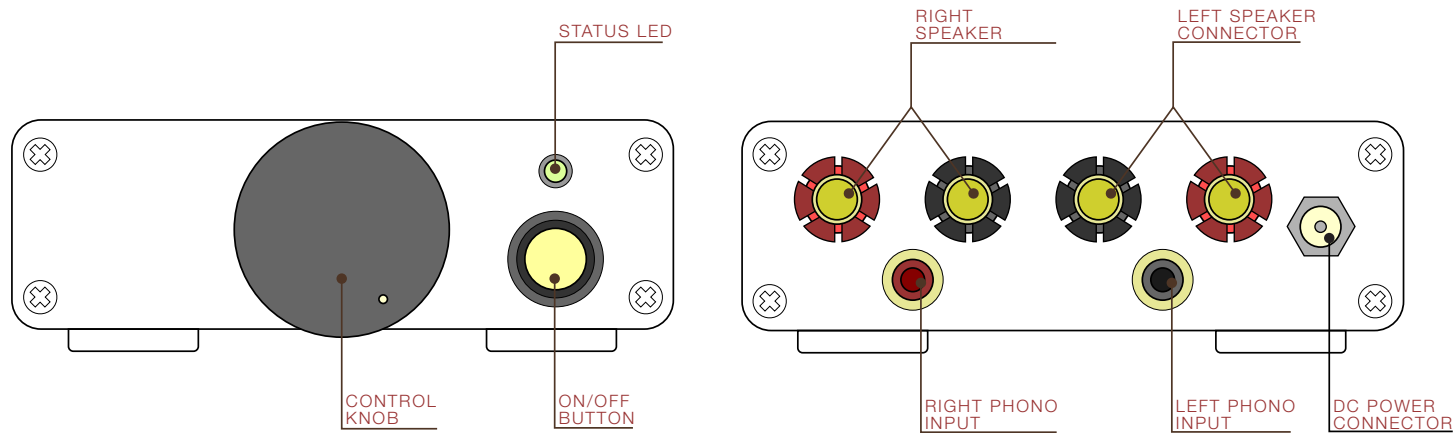

Connecting Speaker Outputs

The amp connects to the speakers via 4 speaker terminals.

The simplest way to connect the speakers is via 4mm banana plugs which simply push in to the speaker terminals.

Also, you can use the 'wire trap' feature of the speaker terminals, by unscrewing the terminal

surround, pushing the bare wire through the exposed hole then screwing the terminal surround back down on the wire.

Connect the positive lead from the left speaker, in to the red speaker connector on the left of the amp.

Connect the negative lead from the left speaker, in to the black speaker connector on the left of the amp.

Connect the positive lead from the right speaker, in to the red speaker connector on the right of the amp.

Connect the negative lead from the right speaker, in to the black speaker connector on the right of the amp.

Connecting Power Supply

Ensure the Amp is in stand by mode by pressing the power button until the button sticks out.

Connect the 12V DC connector from the power supply, to the socket on the back of the amp.

Now power up the amp by pressing the power button.

Connecting Signal Inputs

The audio signal goes in to the amp via 2 phono connectors on the rear of the chassis.

Connect the left audio signal input, to the left (black) phono connector.

Connect the right audio signal input to the right (red) phono connector.

Connection Diagram

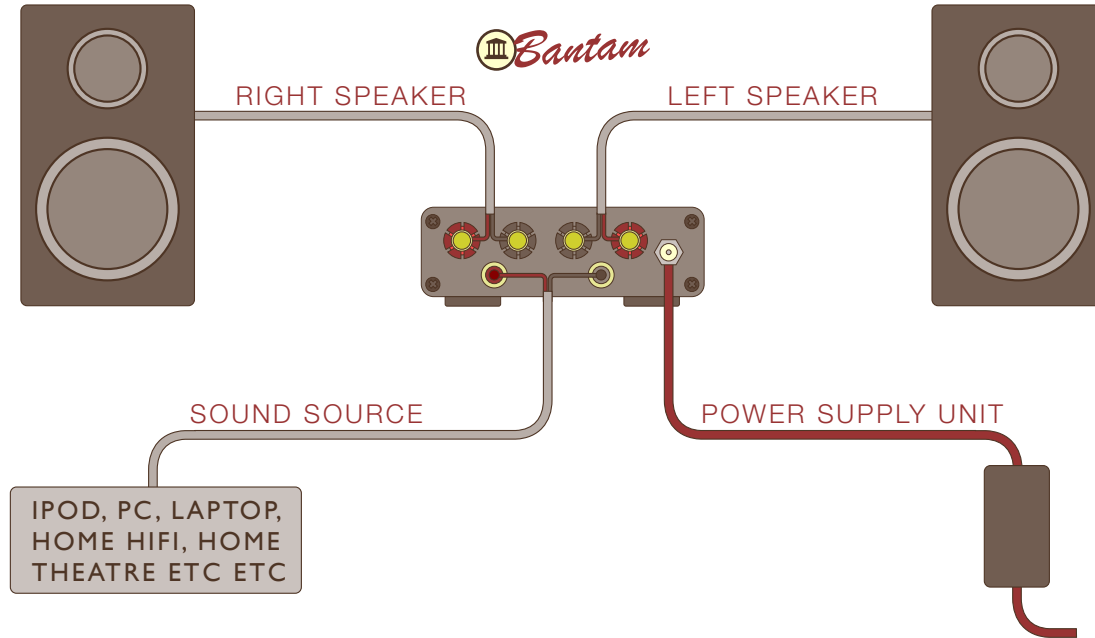

Controls

Turning ON

- Ensure All wires are securely connected to the amplifier.
- Make sure the volume level is not set too high.
- Now press the Power Button and slowly increase the volume.

Setting the Volume

- Turn the knob clockwise to increase the volume.
- Turn the knob anti clockwise to decrease the volume.

Optimisation

After years of Audio design and installation, we have built up some tips which would help optimise any speaker setup when used in domestic sized rooms.

The size and shape of the room determines its low frequency response. For the ideal level frequency response speakers should be facing down the longest length of the room.

Moving loudspeakers closer to the wall increases their low frequency output. Corner positions give the maximum possible low frequency output, and the most level low frequency response, since all the room modes are being driven.

However, many quality loudspeakers are designed to give a level low frequency response at a recommended distance from the wall, whilst a smaller number are designed for placement against the wall. Check with your speaker manufacturer for more information.

Middle and high frequencies are mostly affected by room furnishings and reflective surfaces such as glass windows. Closing curtains for example can dramatically alter the sound the listener experiences.

Speaker cables should go from the amp directly to the speakers. Avoid unnecessarily long wires; and wires with a low current capacity. Expensive or exotic speaker cables will make little or no difference to the sound produced by the speakers.

Amp should be roughly equal distance from either speaker. Avoid having one audio wire much longer than another.

For optimal signal to noise ratio of the signal input, the best practice is to set the 'volume' level from the source to maximum and turn the power amplifier volume to minimum.

Then while listening to your favorite audio track, gradually increase the volume on the power amplifier, until the volume level is appropriate.

Note We have a more technical version of these guidelines in the technical section on our website www.templeaudio.net

Trouble Shooting

No sound output from speakers

- Make sure the Amplifier is turned ON, by pressing the ON button. The LED will glow, to indicate the Amplifier is on.
- Make sure the volume level is not set to minimum by rotating the volume knob clockwise.
- Make sure the appropriate signal inputs, and outputs are connected properly (see page 6)
- Make sure there is no electrical shorting of the loudspeaker output terminals, as this will put the amp into protection mode where the sound output is disabled.

Amplifier will not turn on

- Make sure the appropriate 12v power supply is connected to the 2.1mm DC (center pin positive) socket on the rear of the unit.

Audio output inconsistent or distorted

- Ensure the speaker impedance is 4 ohms or greater.

Audio hum from the speakers

- Use quality screened interconnects between the audio signal source and the Bantam signal input connectors.
- Ensure the Bantam is an adequate distance from any sources of audio frequency interference, such as equipment which may include powerful mains transformers.

Warranty Information

All temple audio electronic products come with a 1 year manufacturers warranty.

Within this time we will repair or replace any unit which is defective or has become defective through normal use.

This warranty does not apply to accessories or damage caused where repairs have been made or attempted by others.

This warranty gives you specific legal rights and you may have other rights which vary in certain countries.

Our products are designed to the highest standards with reliable digital technology and high quality components.

With correct use your product should last a lifetime.

If you have a specific problem or question get in touch our after salesstaff will be happy to help

Contact

Temple Audio LTD

A family business, Registered in England
23 James Street
Sale
Cheshire
M33 3GY

Company Registration Number: 06899384

Contact information:
sales@templeaudio.net

www.templeaudio.net

TEMPLE 
audio

www.templeaudio.net